

◎ POWER RATING

Intermittent rating kW(PS) / rpm	Max. torque N.m(kg.m) / rpm	Fuel consumption g/kW.h(g/PS.h) / rpm
294 (400) / 2,100	1588 (162) / 1,400	217 (160) / 2,100

1. The engine performance corresponds to ISO 3046.
2. Continuous power rating is to 250kW(340ps) @2100rpm.

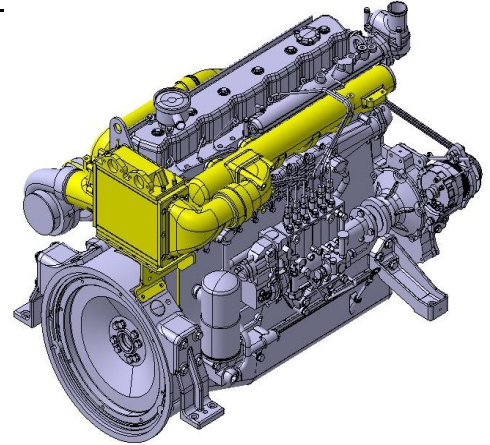

◎ MECHANICAL SYSTEM

- Engine Model PU126TI
- Engine Type In-line 4 cycle, water cooled
Turbo charged & intercooled
- Combustion type Direct injection
- Cylinder Type Replaceable dry liner
- Number of cylinders 6
- Bore x stroke 123(4.84) x 155(6.1) mm(in.)
- Displacement 11.051(674.5) lit.(in³)
- Compression ratio 17 : 1
- Firing order 1-5-3-6-2-4
- Injection timing 14° BTDC
- Compression pressure Above 28 kg/cm²(398 psi) at 200rpm
- Dry weight Approx. 925 kg (2039 lb)
- Dimension (LxWxH) 1,223 x 890 x 1,095 mm
(48.1 x 35.0 x 43.1 in.)
- Rotation Counter clockwise viewed from flywheel
- Fly wheel housing SAE NO.1M
- Fly wheel Clutch NO.14M

◎ MECHANISM

- Type Over head valve
- Number of valve Intake 1, exhaust 1 per cylinder
- Valve lashes at cold Intake 0.30 mm(0.0118 in)
Exhaust 0.30 mm(0.0118 in.)

◎ VALVE TIMING

- | | Opening | Close |
|-----------------|--------------|--------------|
| ○ Intake valve | 18 deg. BTDC | 34 deg. ABDC |
| ○ Exhaust valve | 46 deg. BBDC | 14 deg. ATDC |

◎ OPTION & ACCESSORY PARTS

- Engine parts Fly wheel & housing
Intake & exhaust manifold
- Accessory parts Raditor, silencer & air cleaner
- Electrical parts Gauge panel & stop solenoid

◎ FUEL SYSTEM

- Injection pump Zexel in-line "P" type
- Governor RSV type(all speed control)
- Feed pump Mechanical type
- Injection nozzle Multi hole type
- Opening pressure 220 kg/cm² (3,129 psi)
- Fuel filter Full flow, cartridge type
- Used fuel Diesel fuel oil

◎ LUBRICATION SYSTEM

- Lub. Method Fully forced pressure feed type
- Oil pump Gear type driven by crankshaft
- Oil filter Full flow, cartridge type
- Oil pan capacity High level 23 liters (6.1 gal.)
Low level 20 liters (5.3 gal.)
- Angularity limit Front down 25 deg.
Front up 25 deg.
Side to side 15 deg.
- Lub. Oil Refer to Operation Manual

◎ PERFORMANCE CURVE

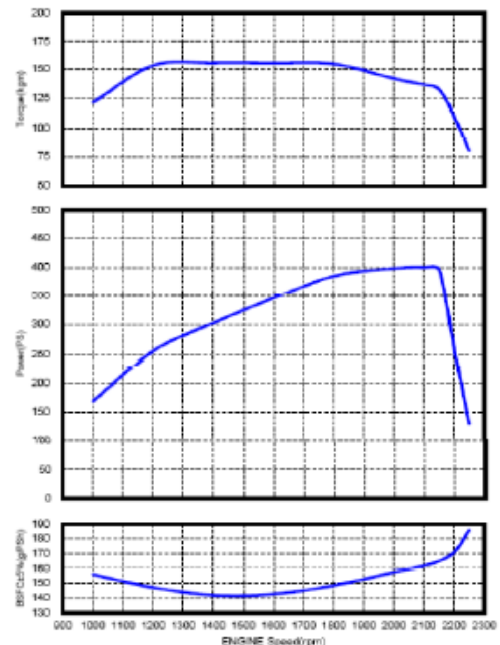

◎ COOLING SYSTEM

- Cooling method Fresh water forced circulation
- Water capacity 19 liters (5.02 gal.)
(engine only)
- Pressure system Max. 0.5 kg/cm² (7.1 psi)
- Water pump Centrifugal type driven by gear
- Water pump Capacity 320 liters (84.5 gal.)/min
at 2,100 rpm (engine)
- Thermostat Wax – pellet type
Opening temp. 83°C
Full open temp. 95°C
- Intercooler Water Cooled

◎ ELECTRICAL SYSTEM

- Charging generator 24V x 45A alternator
- Voltage regulator Built-in type IC regulator
- Starting motor 24V x 6.0kW
- Battery Voltage 24V
- Battery Capacity 150 AH (recommended)
- Starting aid (Option) Block heater

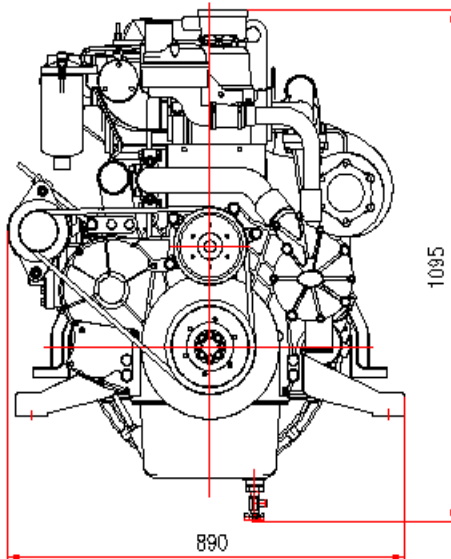

◎ ENGINEERING DATA

- Water flow 310 liters/min @2,100 rpm
- Heat rejection to coolant 27 kcal/sec @2,100 rpm
- Air flow 27 m³/min @2,100 rpm
- Exhaust gas flow 57 m³/min @2,100 rpm
- Exhaust gas temp. 460°C @2,100 rpm
- Max. permissible restrictions
 - Intake system 220 mmH₂O initial
635 mmH₂O final
 - Exhaust system 1,000 mmH₂O max.

◎ INTERCOOLER DATA

- Heat rejection to coolant 16 kcal/sec @2,100 rpm

◆ CONVERSION TABLE

in. = mm x 0.0394	lb/ft = N.m x 0.737
PS = kW x 1.3596	U.S. gal = lit. x 0.264
psi = kg/cm ² x 14.2233	kW = 0.2388 kcal/s
in ³ = lit. x 61.02	lb/PS.h = g/kW.h x 0.00162
hp = PS x 0.98635	cfm = m ³ /min x 35.336
lb = kg x 2.20462	

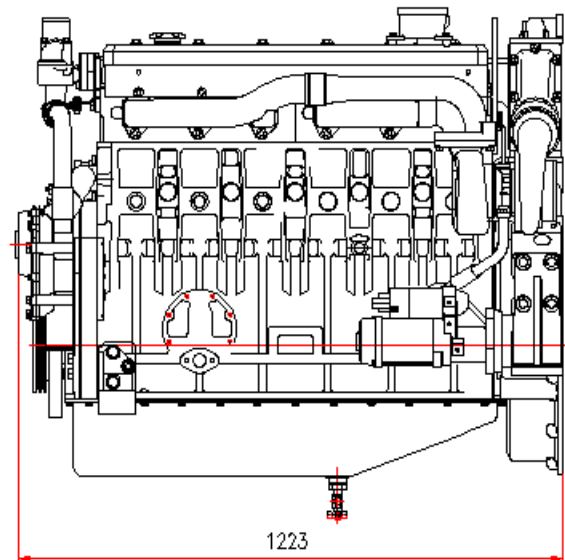

Head office

7-11, Hwasu-Dong, Dong-Gu, Incheon, Korea
TEL : 82-32-211-2222 FAX : 82-32-762-7384

Seoul Office

Doosan Infracore Co. Ltd.,
 22nd Floor, Doosan Tower, 18-12, Euljiro 6-ga, Jung-gu,
 Seoul, Korea.

TEL : 82-2-3398-8521-8535 FAX : 82-2-3398-8509

Web site : www.doosaninfracore.com

※ Specifications are subject to change without prior notice