

## ◎ POWER RATING

| RPM  | Power rating<br>kW(PS) | Torque<br>N.m(kg.m) | Fuel consumption<br>g/kW.h(g/PS.h) |
|------|------------------------|---------------------|------------------------------------|
| 1470 | 564 (767)              | 3668 (374)          | 192 (141)                          |
| 1760 | 610 (829)              | 3305 (337)          | 199 (146)                          |
| 2100 | 622 (846)              | 2834 (289)          | 216 (159)                          |
| 2350 | 625 (850)              | 2540 (259)          | 232 (171)                          |

- Note : 1. The engine performance corresponds to ISO 3046.  
 2. Engines are not to be used for continuous duty. Engines are to be used only for stationary emergency standby fire pump service. According to NFPA 25 engines are to be tested 30 minutes per week at no pump flow and full pump flow once per year.  
 3. If needs continuous duty, Engine power is restricted to 530kW(720ps)@1800rpm.

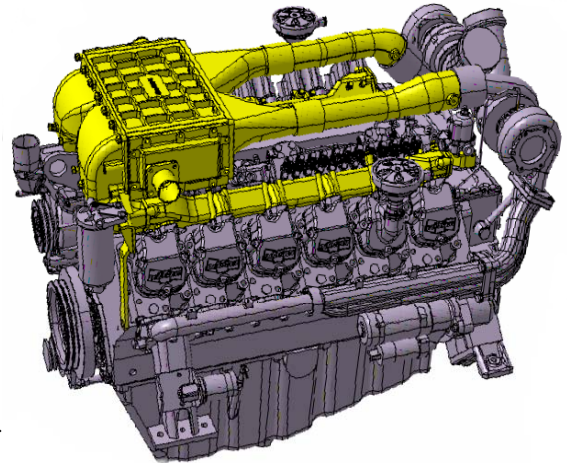

## ◎ MECHANICAL SYSTEM

- Engine Model PU222TI Fire Pump Driver
- Engine Type V-type 4 cycle, water cooled  
Turbo charged & intercooled
- Combustion type Direct injection
- Cylinder Type Replaceable wet liner
- Number of cylinders 12
- Bore x stroke 128(5.04) x 142(5.59) mm(in.)
- Displacement 21.927 (1,338.0) lit.(in<sup>3</sup>)
- Compression ratio 14.6 : 1
- Firing order 1-12-5-8-3-10-6-7-2-11-4-9
- Injection timing 18° BTDC
- Dry weight Approx. 1,650 kg (3,638 lb)
- Dimension 1,453 x 1,140 x 1,292 mm  
(LxWxH) (57.2 x 44.9 x 50.9 in.)
- Rotation Counter clockwise viewed from Flywheel
- Fly wheel housing SAE NO.1
- Fly wheel Clutch NO.14

## ◎ MECHANISM

- Type Over head valve
- Number of valve Intake 1, exhaust 1 per cylinder
- Valve lashes at cold Intake 0.25mm (0.0098 in.)  
Exhaust 0.35mm (0.0138 in.)

## ◎ VALVE TIMING

- |                 | Opening      | Close        |
|-----------------|--------------|--------------|
| ○ Intake valve  | 24 deg. BTDC | 36 deg. ABDC |
| ○ Exhaust valve | 63 deg. BBDC | 27 deg. ATDC |

## ◎ ENGINE EQUIPMENT

- Engine parts Fly wheel & housing  
Intake & exhaust manifold  
Water to air inter cooler
- Electrical parts Stop solenoid of ETS type (only EAYPB)

## ◎ FUEL SYSTEM

- Injection pump Bosch in-line "P" type
- Governor Mechanical type (only EAYPB)  
Electrical type (only EAYPD)
- Feed pump Mechanical type
- Injection nozzle Multi hole type
- Fuel filter Full flow, cartridge type
- Used fuel Diesel fuel oil

## ◎ LUBRICATION SYSTEM

- Lub. Method Fully forced pressure feed type
- Oil pump Gear type driven by crankshaft
- Oil filter Full flow, cartridge type
- Oil pan capacity High level 40 liters ( 10.6 gal.)  
Low level 33 liters ( 8.7 gal.)
- Angularity limit Front down 20 deg.  
Front up 20 deg.  
Side to side 15 deg.
- Lub. Oil Refer to Operation Manual

## ◎ COOLING SYSTEM

- Cooling method Fresh water forced circulation
- Water capacity 23 liters ( 6.07 gal.)  
(engine only)
- Water pump Centrifugal type driven by belt
- Water pump Capacity 702 liters ( 185 gal.)/min  
at 2,350 rpm (engine)
- Thermostat Wax – pellet type  
Opening temp. 71°C  
Full open temp. 85°C
- Water flow in intercooler
  - . Critical velocity 2.0 m/s max.
  - . Pressure drop 0.1 bar

# PU222TI Fire Pump Driver

### ◎ ELECTRICAL SYSTEM

- Charging generator      28.5V x 45A alternator
- Voltage regulator        Built-in type IC regulator
- Starting motor            24V x 7.0kW
- Battery Voltage          24V
- Battery Capacity         200 AH (recommended)
- Starting aid (Option)    Block heater

### ◎ NOISE DATA

- Test Standards            ISO-3744 / JIS-B8005
- Test Condition            1m at the Cylinder Block
- Calculated sound pressure

| RPM  | Power [PS] | Octave Band [dB(A)] |
|------|------------|---------------------|
| 1760 | 829        | 104.3               |
| 2100 | 846        | 107.0               |
| 2350 | 850        | 108.4               |

### ◆ CONVERSION TABLE

- in. = mm x 0.0394            lb/ft = N.m x 0.737
- PS = kW x 1.3596            U.S. gal = lit. x 0.264
- psi = kg/cm<sup>2</sup> x 14.2233      kW = 0.2388 kcal/s
- in<sup>3</sup> = lit. x 61.02            lb/PS.h = g/kW.h x 0.00162
- hp = PS x 0.98635          cfm = m<sup>3</sup>/min x 35.336
- lb = kg x 2.20462

### ◎ ENGINEERING DATA

- Water flow                    702 liters/min @2,350 rpm  
627 liters/min @2,100 rpm  
526 liters/min @1,760 rpm
- Heat rejection to coolant    57.2 kcal/sec @2,350 rpm  
40.9 kcal/sec @2,100 rpm  
34.3 kcal/sec @1,760 rpm
- Heat rejection to CAC        39.3 kcal/sec @2,350 rpm  
33.7 kcal/sec @2,100 rpm  
25.0 kcal/sec @1,760 rpm
- Air flow                        76.1 m<sup>3</sup>/min @2,350 rpm  
70.4 m<sup>3</sup>/min @2,100 rpm  
63.2 m<sup>3</sup>/min @1,760 rpm
- Exhaust gas flow            131.5 m<sup>3</sup>/min @2,350 rpm  
119.2 m<sup>3</sup>/min @2,100 rpm  
108.2 m<sup>3</sup>/min @1,760 rpm
- Exhaust gas temp.            555 °C @2,350 rpm  
543 °C @2,100 rpm  
549 °C @1,760 rpm
- Max. permissible restrictions
  - Intake system                220 mmH<sub>2</sub>O initial  
635 mmH<sub>2</sub>O final
  - Exhaust system              1000 mmH<sub>2</sub>O max.

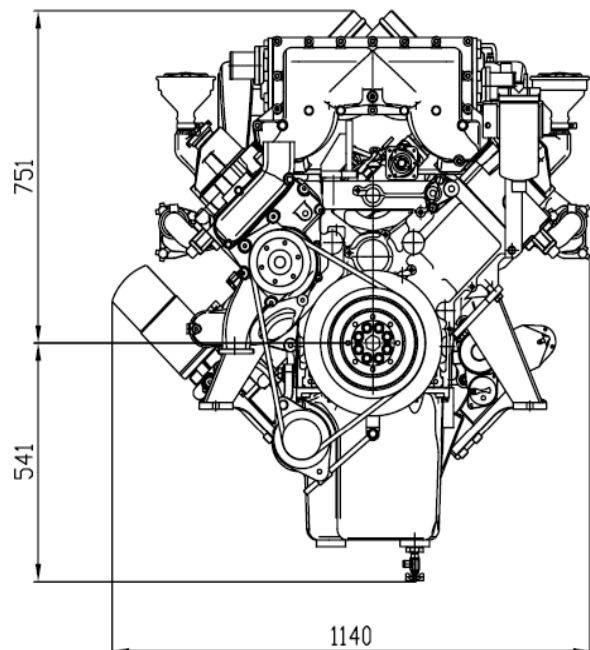
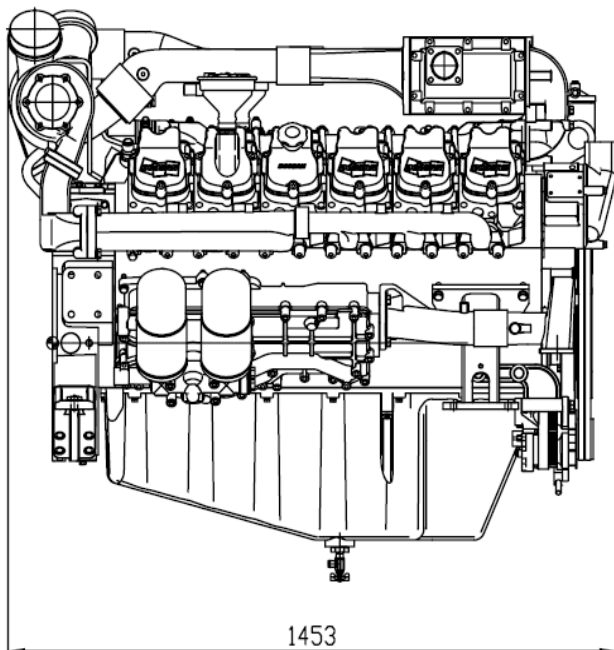

# PU222TI Fire Pump Driver

◎ PERFORMANCE CURVE

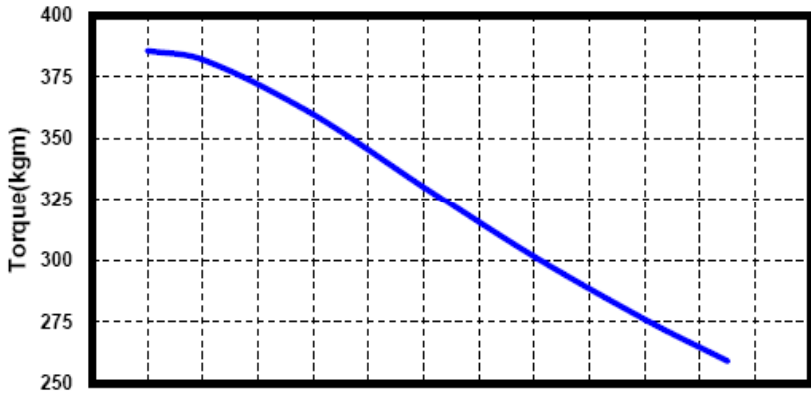

All data is based on the engine operating with fuel system, water pump, lubricating oil pump, air cleaner, and alternator; not included are compressor, fan, optional equipment, and driven components.

Data is based on operation at ISO standard 3046 conditions of 100 kPa barometric pressure, 100 m altitude, and 25 °C intake ambient temperature.

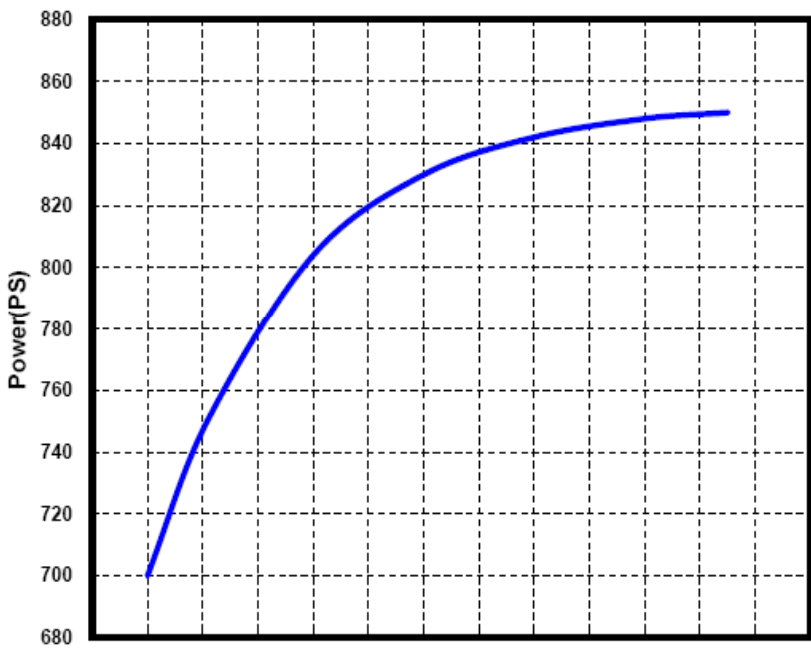

For sustained operation at high altitudes, the fuel rate of the engine should be adjusted to limit performance by 3 % per 300 m above 100 m altitude.

For sustained operation at high ambient temperatures, the fuel rate of the engine should be adjusted to limit performance by 2 % per 11 °C above 25 °C.

Engine is certified at any speed between 1470 and 2350 RPM.

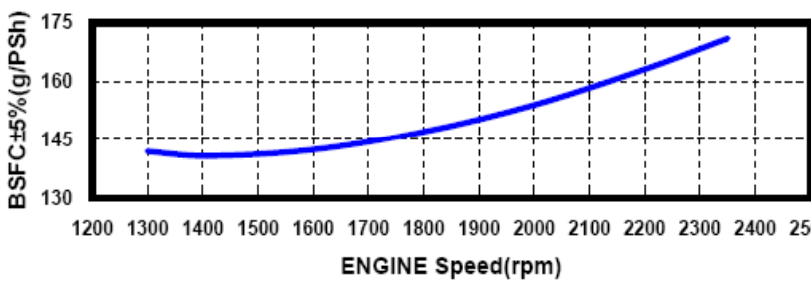

**Head office**  
7-11, Hwasu-Dong, Dong-Gu, Incheon, Korea

**Seoul Office**  
Doosan Infracore Co. Ltd.,  
22nd Floor, Doosan Tower, 18-12, Euljiro 6-ga, Jung-gu,  
Seoul, Korea.  
TEL : 82-2-3398-8400 , e-mail : enginesales@doosan.com  
Web site : www.doosaninfracore.com

※ Specifications are subject to change without prior notice